

802.11ah Wi-Fi HaLow™ SDIO/SPI module with enhanced features for hosted embedded systems

SX-SDMAH (US)



Product Overview

SX-SDMAH (US) is an 802.11ah Wi-Fi HaLow SDIO/SPI module enabled by Morse Micro's MM6108. It features a host SDIO or SPI interface to operate with a processor or a microcontroller. It supports up to 8MHz channel bandwidth to improve the maximum data throughput in the countries allowing 8MHz usage. Its small footprint design with the integrated antenna connector saves the PCB space and allows a more flexible embedded system design. The SX-SDMAH also features high-transmission power to gain more distance and coverage.

Benefits

Data Transfer over Further Distances

The SX-SDMAH features higher transmission power than other Wi-Fi HaLow modules enabled by MM6108 IC. It ensures the best performance in its data throughput over long distances, and also provides wide coverage of Wi-Fi HaLow radio signal.

Improved Data Throughput

The SX-SDMAH supports up to 8MHz channel bandwidth to allow data transmission at up to 32.5Mbps PHY bit rate. It will improve the user experiences with Wi-Fi HaLow in regions where 8MHz channel bandwidth usage is allowed. Improved data throughput also enhances the experience with a large-scale IoT network.

SDIO Host Interface for Linux OS

The SDIO host interface has been widely used in legacy Wi-Fi systems. The SX-SDMAH offers more options for the embedded system design. It also eliminates a performance constraint with certain processors with SPI interface.

SPI Host Interface for RTOS

The SX-SDMAH supports the SPI host interface for RTOS embedded systems.

Small Footprint

The SX-SDMAH is the small footprint module integrating the antenna connector to save PCB space and simplify the PCB design.

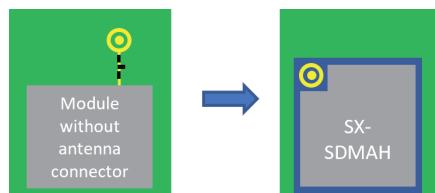

Embedded System Examples

- Wi-Fi HaLow™ access point
- Gateway
- Ethernet wireless bridge
- Wi-Fi extender
- IP camera, thermography camera
- 3D scanner
- GNSS receiver
- Vehicle telemetry devices
- High-end sensors (e.g. vibration sensors)
- Access control system



Key Features

- Complies with IEEE 802.11ah
- 1/2/4/8MHz channel bandwidth support
- Up to 32.5Mbps PHY bit rate
- Transmission power of +23dBm or higher (target)
- Access point and station mode
- SDIO/SPI interface
- Enhanced Open/WPA3 security
- Power-saving mode
- Modular certification for the United States and Canada (plan)
- Linux/Free RTOS driver support

Specifications	
Name	SX-SDMAH (US)
Chipset	MM6108
Host Interface	SDIO for Linux SPI for FreeRTOS
Wi-Fi Standard	802.11ah Wi-Fi HaLow
Antenna Connector	MHF1
Operating Voltage	VDD: 3.3V VDDIO: 1.8V or 3.3V VDDFEM: 3.3V or 5V (US)
Operating Environment	Temperature: -40 - 85°C Humidity: 15% - 95% w/o condensation
Storage Environment	Temperature: -40 - 85°C Humidity: 15% - 95% w/o condensation
Size	17mm × 18mm × 2.65mm
Weight	T.B.D.
Package Type	60-pin LGA
Modular Certification	US, Canada, Japan (under testing)

Product SKUs		
Part Number	MoQ	Description
SX-SDMAH (US)	500	Reel
SX-SDMAH-SP (US)	1	Cut Reel
SX-SDMAH-EVK (US)	1	Evaluation kit with Raspberry Pi
SX-SDMAH-EVB (US)	1	Raspberry Pi HAT Board

Evaluation

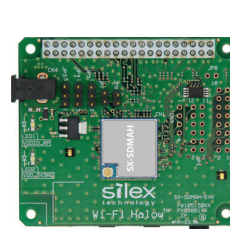

SX-SDMAH-EVK (US)

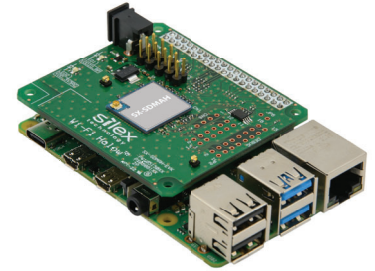

SX-SDMAH-EVK (US) +
Raspberry Pi4 model B

- SX-SDMAH-EVK(US) Linux Driver Evaluation Image
- Linux kernel version 5.10
- hostapd/wpa_supplicant version 2.10
- Configurable to an access point or a station
- SX-SDMAH(US) command line tool
- Network test command: ping, iperf, iw, etc.

- 1 Prepare the required hardware
 - SX-SDMAH-EVK or SX-SDMAH-EVB and Raspberry Pi 4 model B
- 2 Prepare the evaluation OS image
 - A micro-SD card with Linux image contained in SX-NEWAH-EVK (US)
 - Or, download the evaluation image from Silex' s website and load into a micro-SD card
- 3 Refer to the evaluation setup guide to start
 - Instructions in the user guide available on our website

For more information on SX-SDMAH, please visit:
www.silextechnology.com/connectivity-solutions/embedded-wireless/sx-sdmah

Block Diagram

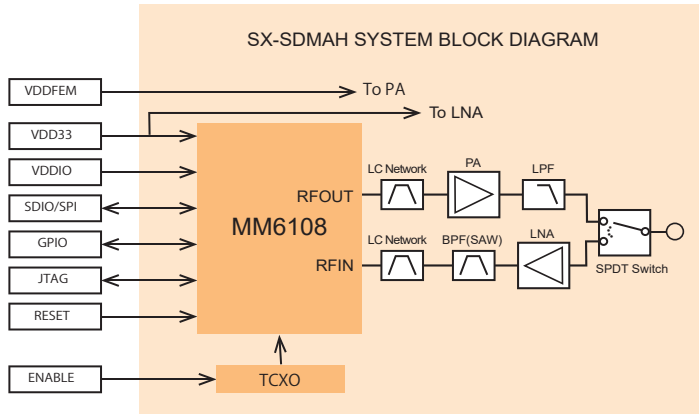

Mechanical Specifications

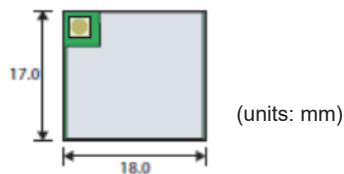

sillex technology is a registered trademark of sillex technology, Inc. Other product or brand names may be registered trademarks or trademarks of their respective owners.
 Technical information and specifications are subject to change without notice. © 2020 sillex technology, Inc. All rights reserved.

sillex global sales & support locations



US Office
 sillex technology america, Inc.
 +1-657-218-5199
www.silextechnology.com
sales@sillexamerica.com

Europe Office
 sillex technology europe, GmbH
 +49-2154-88967-0
 Germany toll free 0800-7453938
www.silextechnology.com
contact@sillexeurope.com

China
 sillex technology beijing, Inc.
 +86-10-8497-1430
www.sillex.com.cn
contact@sillex.com.cn

Corporate Headquarters
 sillex technology, Inc.
 +81-774-98-3781
www.sillex.jp
support@sillex.jp

